



Hybrid power generation system using solar and wind energy

Jagruti Patil

Student, M.E. Electrical Power System, Yadavrao Tasgaonkar Institute of Engineering and Technology, Chandhai, Karjat, Raigad, Maharashtra, India

Abstract

With increasing demand for energy and with fast depleting conventional sources of energy such as coal, petroleum, natural gas, etc. the non-conventional sources of energy such as energy from sun, wind, biomass, tidal energy, geo-thermal energy and even energy from waste material are gaining importance. Wind and solar energy are complementary to each other, which makes the system to generate electricity almost throughout the year. The main components of the Wind Solar Hybrid System are wind aero generator and tower, solar photovoltaic panels, batteries, cables, charge controller and inverter. The Wind - Solar Hybrid System generates electricity that can be used for charging batteries and with the use of inverter we can run AC appliances.

Keywords: solar, wind energy, hybrid power generation

1. Introduction

Solar Energy can be converted into electrical energy with the help of Photo Voltaic (PV) Cell. Electric Power generation from Solar cell is based on principle of photovoltaic effect. When light energy hits the cell the electron hole diffusion occurs that creates electric field. Electric field produces the current to flow in one direction and hence electric power is extracted from the circuit. To maintain generation system reliability Hybrid Power Generation system is proposed. Which consists of Wind power generation system with Solar system. Wind energy is not a constant source of energy. It varies continuously and gives energy in sudden bursts. Standalone wind with solar PV is known as best hybrid combination of renewable energy systems.

2. Problem Formulation

Electric power generation from solar Energy is based on Photoelectric effect .Where light energy is converted into electric energy. It's completely environment friendly. Though the solar energy is available in large quantity there are many problems associated when it is used as a power generation source with the help of photovoltaic cells.

The insolation level which makes it impractical to directly connect them to the load without any storage devices or utility grid interface. Even in the hottest regions of the earth, the solar radiation flux available rarely exceeds 1kW/m² and the total radiation over a day is at best about 7 kWh/m². These are low values from point of view of technological utilization.

Standalone Solar Energy generation has several Efficiency Issues Solar panels are currently not highly efficient although efficiency continues to improve with technological advances. The efficiency can be dramatically affected by many factors, including regular, everyday issues like the amount of shade (from trees, structures...), wind, dust, snow, angle of the panels, amount of daylight, access to direct sunlight, solar intensity resulting in Non Uniform Solar radiation.

Hence In order to meet continuous load demand additional power generating resource is adopted

The main objective of this thesis is the development of a Hybrid Energy System combination of

- Photovoltaic (PV) system and
- Wind turbine generator system

3. Proposed System

Intermittent energy resources and energy resources unbalance are the most important reason to install a hybrid energy supply system. Electric Power generation from solar energy is based on the Photovoltaic Effect. Where photo stands for light and voltaic implies producing voltage. Photovoltaic (PV) systems convert light directly into electricity (using semi-conductor technology). Power generation from wind can be done by converting Kinetic Energy of Wind to Mechanical power. The system components are as follows.

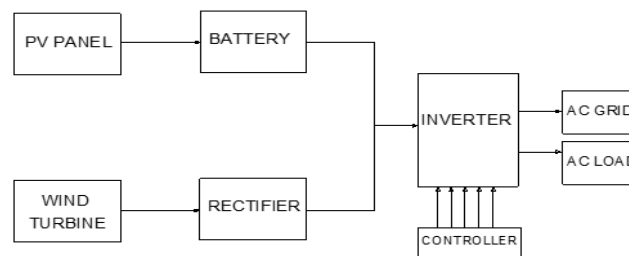

Fig 1: Proposed System Block diagram

A hybrid arrangement of combining the power harnessed from both the wind and the sun and stored in a battery can be a much more reliable and realistic power source. Proposed system contains

- Solar photovoltaic system
- Wind turbine generator
- DC-AC conversion assembly

System control & present technologies are been studied. Overall system is simulated using MATLAB environment. Since system is use for both Grid & individual AC loads output parameters are verified using Simulink with either grid connected or disconnected using breaker switch. In order to analyze the operation of microgrid system both the modeling and controlling of the system are important issues. Hence the control and modeling are also the part of this thesis work.

3.1 Solar power generation

The basic ingredients of PV cells are semiconductor materials, such as silicon. Polycrystalline Thin-Film Photovoltaic Technologies are widely used nowadays. A simple solar cell is a pn junction diode the n region is heavily doped and thin so that the light can penetrate through it easily. The p region is lightly doped so that most of the depletion region lies in the p side. The penetration depends on the wavelength and the absorption coefficient increases as the wavelength decreases. Electron hole pairs (EHPs) are mainly created in the depletion region and due to the built-in potential and electric field, electrons move to the n region and the holes to the p region shown in fig.2. When an external load is applied, the excess electrons travel through the load to recombine with the excess holes. Electrons and holes are also generated with the p and n region some of the EHPs generated in these regions can also contribute to the current. Typically, these are EHPs that are generated within the minority. Radiation is absorbed in the depletion region and produces electrons and holes. These are separated by the built-in potential. Depending on the wavelength and the thickness different parts of the device can absorb different regions of the solar spectrum.

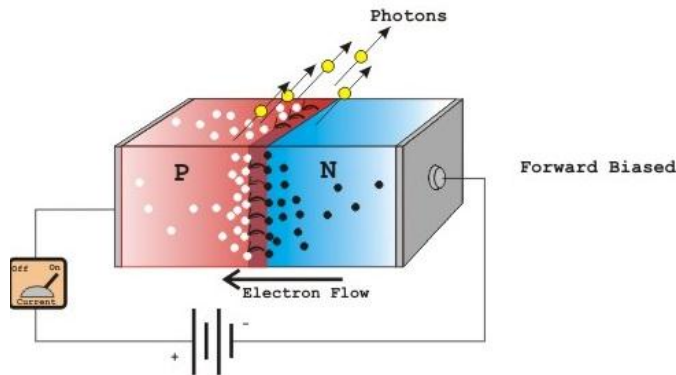

Fig 2: Principle of operation of a p-n junction solar cell

3.1.1 Photovoltaic Module

Because of the low voltage generation in a PV cell (around 0.5V), several PV cells are connected in series (for high voltage) and in parallel (for high current) to form a PV module for desired output. In case of partial or total shading and at night there may be requirement of separate diodes to avoid reverse currents. The p-n junctions of mono-crystalline silicon cells may have adequate reverse current characteristics and these are not necessary. There is wastage of power because of reverse currents which directs to overheating of shaded cells. At higher temperatures solar cells provide less efficiency and installers aim to offer good ventilation behind solar panel. umber of Solar cells together form PV module individual solar

cell voltage is typically 0.5V.

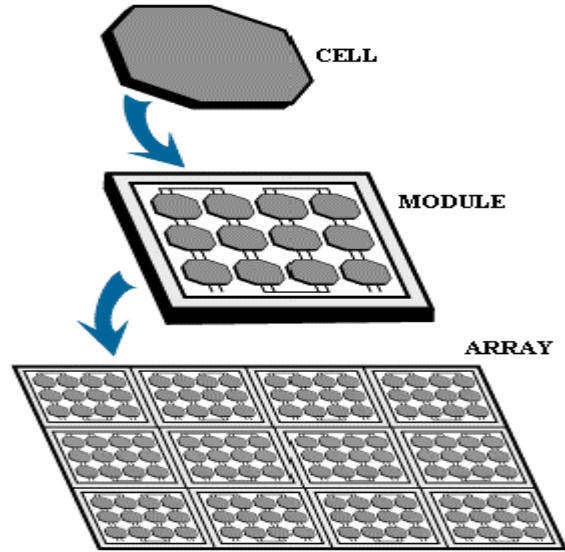

Fig 3: Photovoltaic system

3.2 Wind Energy Conversion System

Wind energy is the kinetic energy associated with the movement of atmospheric air. It has been used for hundreds of years for sailing, grinding grain and for irrigation. Wind energy systems convert this kinetic energy to more useful forms of power. Wind energy systems for irrigation and milling have been in use since ancient times and at the beginning of the 20th century it is being used to generate electric power. Wind turbines transform the energy in the wind into mechanical power, which can then be used directly for grinding etc. or further converting to electric power to generate electricity.

The wind turbine is the heart of the wind energy conversion system (WECS). Wind rotates the blades of the wind turbine, which drives electrical generator to produce electrical power. Usually wind passes over the blades, generating lift and exerting a turning force. Inside the nacelle the rotating blades turn a shaft then goes into a gearbox. The gearbox helps in increasing the rotational speed for the operation of the generator and utilizes magnetic fields to convert the rotational energy into electrical energy. Then the output electrical power goes to a transformer, which converts the electricity to the appropriate voltage for the power collection system. A wind turbine extracts kinetic energy from the swept area of the blades.

The power contained in the wind is given by the kinetic energy of the flowing air mass per unit time [28]. The equation for the power contained in the wind can then be written as

$$\begin{aligned}
 P_{\text{air}} &= \frac{1}{2} (\text{air mass per unit time}) (V_{\infty})^2 \\
 &= \frac{1}{2} (\rho A V_{\infty}) (V_{\infty})^2 \\
 &= \frac{1}{2} \rho A V_{\infty}^3 \tag{8.1}
 \end{aligned}$$

Although Eq. (3.1) describes the availability of power in the wind, power transferred to the wind turbine rotor is reduced

by the power coefficient C_p .

$$C_p = \frac{P_{\text{wind turbine}}}{P_{\text{air}}}$$

A maximum value of C_p is defined by the Betz limit, which states that a turbine can never extract more than 59.3% of the power from an air stream. In reality wind turbine rotors have maximum C_p values in the range 25-45%.

$$P_{\text{wind turbine}} = C_p \times P_{\text{air}} \quad (8.2)$$

It is also conventional to define a tip speed ratio λ as

$$\lambda = \frac{\omega R}{V_{\infty}} \quad (8.3)$$

3.2.1 Wind Turbine System

In wind energy generation, kinetic energy of wind is converted into mechanical energy and subsequently into electrical energy. Wind has considerable amount of kinetic energy when blowing at high speeds. This kinetic energy when passes through the blades of the wind turbines, it is converted into mechanical energy and rotates the wind blades. When the wind blades rotate, the connected rotor also rotate, thereby producing electricity with the help of a generator connected to the rotor.

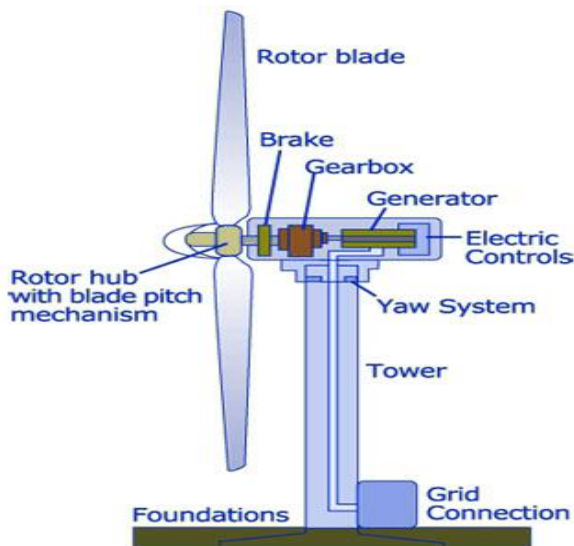

Fig 4: Wind turbine system

The wind turbine is a three bladed, upwind, horizontal-axis wind turbine with a rotor diameter of 82.5m. The turbine rotor and nacelle are mounted on top of a tubular tower giving a rotor hub height of 80m. The machine employs active yaw control (designed to steer the machine with respect to the wind direction), active blade pitch control (designed to regulate turbine rotor speed), and a generator/power electronic converter system. The wind turbine features a distributed drive train design wherein the major drive train components including main shaft bearings, gearbox, generator, yaw drives, and control panel are attached to a bedplate. Wind turbine

parts are shown in fig.8.1

3.2.2 Wind Turbine Control System

The wind turbine uses a power converter system that consists of a converter on the rotor side, a DC intermediate circuit, and a power inverter on the grid side. The converter system consists of a power module and the associated electrical equipment. Variable output frequency of the converter allows operation of the generator.

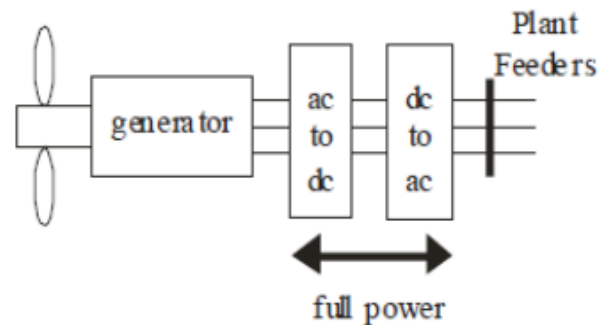

Fig 5: wind turbine generator assembly

The AC output of wind generator is converted to DC & again reconverted to AC to have Regularised AC waveform. The power converter acts as a buffer between the grid and the electric generator, thus, any transients occurring in the grid are not translated to the electric generator. Under normal or fault transients, the power converter can be fully controlled. However, one should realize that the power converter has a current limit to protect the output current of the power semiconductors (e.g. IGBT and diodes), and when the grid voltage is low during a fault transient disturbance, the maximum output power that can be delivered to the grid is also limited. Thus, the pitch controller will limit the rotor speed from over-speeding avoiding a run-away situation.

4. Conclusion

The modeling of hybrid power system configuration will be done in Matlab/Simulink environment. The present work will be based on Collating two renewable power resources meeting load demand of AC grid as well as individual AC loads. Hybrid system output is tested in simulation. It is Possible to improve over all PV system efficiency with addition of several energy efficient components into the system. Enabling the designer to design a system with smaller (and less costly) PV arrays and batteries while still allowing the PV system to provide adequate coverage to the base.

5. References

1. Wai RJ, Wang WH, Lin CY. High-Performance Stand-Alone Photovoltaic Generation System, IEEE Trans. on Industrial Electronics. 2008; 55(1):240-250.
2. Katsuhiko Nomoto. Thin-Film Silicon Solar Cell And Module Applications, Sharp Corporation, Solar Systems Group, Thin-Film PV division Katsuragi-shi, NARA 639-2198.
3. Chan YK, Gu JC. Modeling and control of stand-alone photovoltaic generation system. IEEE International

- Conference on Power System Technology (POWERCON). 2010, 1-7.
4. Bhadra SN, Kastha D, Banerjee S. Wind Electrical Systems, Oxford University Press, New Delhi, 2009.
 5. Bose BK. Modern Power Electronics and AC Drives ,” Prentice-Hall, Inc., New Delhi, 2002.
 6. Girgis A, Brahma S. Effect of Distributed Generation on Protective Device Coordination in Distribution System, in Large Engineering Systems Conf. Power Engineering. 2001; 115-119.
 7. Wai RJ, Wang WH, Linb CY. High-Performance Stand-Alone Photovoltaic Generation System, IEEE Trans. on Industrial Electronics. 2008; 55(1):240-250.
 8. Katsuhiko Nomoto. Thin-Film Silicon Solar Cell And Module Applications, Sharp Corporation, Solar Systems Group, Thin-Film PV division Katsuragi-shi, NARA 639-2198.
 9. Chan YK, Gu JC. Modeling and control of stand-alone photovoltaic generation system” IEEE International Conference on Power System Technology (POWERCON). 2010, 1-7.
 10. Adejumbi IA, Oyagbinrin SG, Akinboro FG, Olajide MB. Hybrid Solar And Wind Power: An Essential For Information Communication Technology Infrastructure And People In Rural Communities, 2011.
 11. Ellen Ferry. Wind Power-An answer For Future, 2009.
 12. Dr. Naganagouda H, Hiregowadara Yerranagouda,” Demonstration Of Hybrid system(Wind And Solar) For Domestic Lighting Application
 13. Bhadra SN, Kastha D, Banerjee S. Wind Electrical System, Oxford University Press, New Delhi, 2009.
 14. Bose BK. Modern Power Electronics and AC Drives, Prentice-Hall, Inc., New Delhi, 2002.
 15. Girgis A, Brahma S. Effect of Distributed Generation on Protective Device Coordination in Distribution System, in Large Engineering System Conf. Power Engineering. 2001, 115-119.
 16. Pena R, Clare JC, Asher GM. Doubly fed induction generator using back to back PWM converters and its application to variable speed wind energy generation,” in Proc. IEE Electr. Power Appl. 1996; 143(3):231-241.
 17. Kjaer SB, Pedersen JK, Blaabjerg F. A review of single-phase grid-connected inverters for photovoltaic modules,” IEEE Trans. Ind. Appl. 2005; 41(5):1292-1306.
 18. Khadkikar V, Member IEEE, Rajiv Varma K, Member IEEE, Ravi Seethapathy, Senior Member, IEEE,” Grid Voltage Regulation Utilizing Storage Batteries in PV Solar – Wind Plant based Distributed Generation System.
 19. Venkatesan M, Vineeth Vijayaraghavan Director - Research & Outreach “Hybrid Battery Charging System Using Solar PV and Utility Grid”
 20. Bong -Yeon Choi, Yong-Su Noh, Young-Hyok Ji, Byoung-Kuk Lee, Chung-Yuen Won Sungkyunkwan University “Battery-Integrated Power Optimizer for PV-Battery Hybrid Power Generation System Bong”
 21. Nehrir MH, Wang C, Strunz K, Aki H, Ramakumar R, Bing J, Z. Miao and Z. Salameh “A Review of Hybrid Renewable/Alternative Energy Systems for Electric Power Generation: Configurations, Control, and Applications” Special Task Force of the IEEE PES Renewable Energy Technologies Subcommittee, Energy Development and Power Generation Committee.
 22. Kellogg WD, MH. Nehrir, G Venkataramanan, V Gerez. Generation unitsizing and cost analysis for stand-alonewind, photovoltaic, and hybrid wind/PV systems, IEEE Trans. Energy Convers. 1998; 13(1):70-75.
 23. Chedid R, Akiki H, Rahman S. A decision support technique for the design of hybrid solar-wind power systems,” IEEE Trans. Energy Convers. 1998; 13(1):76-83.
 24. Borowy B, Salameh Z. Methodology for the optimally sizing the combination of a battery bank and PV array in a wind/PV hybrid system, IEEE Trans. Energy Convers. 1996; 11(2):367-375.
 25. Giraud, Salameh ZM. Steady-state performance of a grid connected roof top hybrid wind-photovoltaic power system with battery storage,” IEEE Trans. Energy Convers., vol. 2001; 16(1):1-7.
 26. IEEE. Journal Of Photovoltaics, Vol. 4, No. 4 , July 2014 “Nanostructured Electrodes Improve the Fill Factor of Organic Photovoltaics” Jonathan H. Beck, Student Member, IEEE, Biswajit Ray, Member, IEEE, Richard R. Grote.
 27. Thin-film Silicon Technology for Highly-Efficient Solar Cells René A. C. M. M. van Swaaij, Arno H. M. Smets, and Miro Zeman.
 28. Crystalline Silicon Photovoltaic Cell Technology: Meeting The Challenge Mr Utility Power” Dan E. Arvizu, Sandia National Laboratories
 29. First Solar, LLC, 12900 Eckel Junction Rd., Perrysburg, OH 43551, V.G Karpov, R. R. Harju and G. Dorer “Nonuniform Power Generation In Polycrystalline Thin Film Photovoltaics”
 30. Bube RH. Photovoltaic Materials, Imperial College Press, 1998.
 31. Principles Of Doubly-Fed Induction Generators (DFIG)” by the staff of Lab-Volt Ltd.
 32. Modeling and Control of Hybrid Systems Solar / Wind / Battery Using Three Inputs DC -DC Boost Converter” S. Sathya1, B. Vinoth Kumar
 33. Outdoor evaluation of crystalline and amorphous silicon technologies” T.S. Surendrai, C.S. Ra And G. Tulasi Ram Das
 34. Bhadra SN, Kastha D, Banerjee S. Wind Electrical Systems,” Oxford University Press, New Delhi, 2009.
 35. Nehrir MH. Wang C, Strunz K, Aki H, Ramakumar R, J. Bing, Z. Miao, Salameh Z.
 36. A Review of Hybrid Renewable/Alternative Energy Systems for Electric Power Generation.