



## Analytical synthesis of aeroplane landing gear by using compactness algorithm

Hitesh Kumar Prajapat, Kalyan Singh

Assistant Professor, Department of Mechanical Engineering, MITRC, Alwar, Rajasthan, India

### Abstract

There are infinite number of Grash of mechanism solutions present in Burmester curve to attain the number of predefined coupler positions. By providing some constraints namely extremity of transmission angle, Grash of conditions and minimum perimeter condition or compactness condition. A synthesized mechanism can be obtained from these solutions, whose coupler point passes through predefined points. In this work an aeroplane landing gear mechanism is designed by the help of compactness algorithm in which Filemon's construction is also applied to already defined constraints for getting a defect free synthesized mechanism. A defect free mechanism will attain or approximate all the prescribed precision positions by path generator. In this work path generator is produced by taking four precision positions points. This work proposes an algorithm named as compactness algorithm and one application to verify. Algorithm is codified in MATLAB due to its vectorised operation in less time.

**Keywords:** filemon's construction, burmester curve, transmission angle, circuit defect and compactness

### 1. Introduction

#### 1.1 Background and objective

In kinematic synthesis of mechanism designer use mechanism output parameters like displacement, prescribed coupler positions as input to find mechanism dimensions that includes lengths of different links, fixed and moving pivot coordinates as output. Kinematic synthesis is further divided into three subcategories: Motion generation, path generation and function generation. These three are differentiate only by mechanism output parameter i.e. prescribed precision positions. These positions can be easily attained by synthesized defect free mechanism produced from perimeter algorithm. In case of motion generation mechanism output parameter is rigid body positions while in path generation it is rigid body path points. In function generation link, angular displacements are the mechanism output parameters.

Objective is to develop an algorithm which produce Burmester curve containing infinite number of mechanism solutions then removing a segment from this curve which contains defected mechanisms. To remove that segment Filemon's construction is used. From the remaining mechanism solutions, finding one or more defect free four - bar planar linkage systems, which are having complete rotation of crank and, follows all the constraints like limits of transmission angle, Grash of condition and mechanism minimum perimeter.

#### 1.2 Literature review

The work in the province of synthesizing of four-bar mechanism is done through graphical method as well as by analytical method. Analytical method contains the work of Peter J. Martin and Kevin Russell [1]. They proposed an algorithm for generating planar four-bar motion generator having some constraints of transmission angle, minimal perimeter and Grashof condition. G. Erdman [2] work provides

a method of modelling the dyads by complex numbers in several different equation forms for three prescribed positions of either path or motion generation with prescribed timing. More work in the analytical synthesis is done by Garcia, Viadero and Fernandez [3], they purpose an approach which uses exact differentiation to obtain gradient elements for function generation, path generation and rigid body counsel in kinematic synthesis of mechanism. Daniel A. Brake and David H Myszka [4] gave a complete solution of Alt-Burmester curve synthesis problems for four-bar linkages which is an analytical approach. Lebedev [5] gave a method for synthesis of 2-D mechanism by using vector relationship between centrode and link lengths. In the work of Khare and Dave [6] four-bar crank rocker mechanism is optimized by maximizing, the minimum transmission angle. The work in the province of function generation, by Chiang [7] who proposed a method of synthesis of four bar function generators by means of equations of three relative poles, instead of conventional four opposite poles.

### 2. Burmester curve generation

The planar four-bar mechanism is divided into two dyads i.e. a set of two links connected together with a joint. As shown in fig. 1 a planar four-bar linkage has two dyads, left dyad including vector  $\vec{w}$  and  $\vec{z}$  and right-hand dyad including vector  $\vec{s}$  and  $\vec{u}$ . Vector  $\vec{w}$  and  $\vec{u}$  represents length of crank and follower respectively

The vector  $r_n$  is representing the distance and direction of motion of coupler point, when the crank rotate counter clockwise by an angle  $\beta_j$  w.r.t to the positive x-axis.  $\alpha_j$  is the angle turned by the vector  $\vec{z}$ . Vector  $\vec{z}$  represents the distance between moving pivot and coupler point. Vector  $\vec{z}$  makes an angle  $\Phi$  to the x-axis. In the fig. 2, the position of both dyads shown according to which the angle turned by follower is  $\gamma_j$  to

reach  $j^{th}$  position. By loop closure equation:

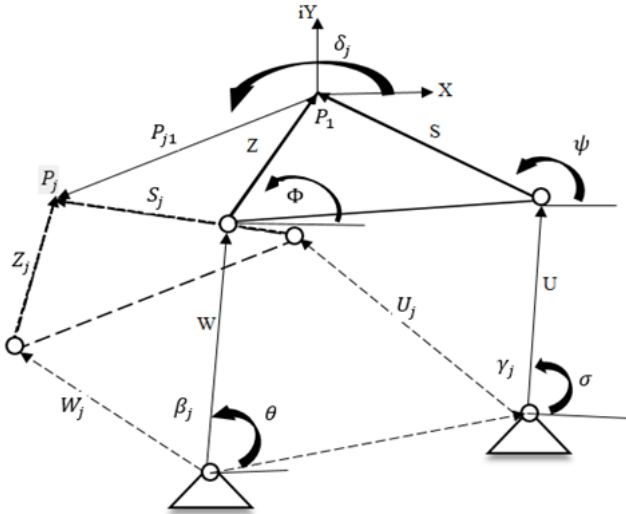

**Fig 1:** Four-bar mechanism with both dyads at its initial and  $j^{th}$  position

For left side dyad:

$$W_1 e^{i\theta} + Z_1 e^{i\Phi} + P_{j1} e^{i\beta_j} - Z_1 e^{i(\Phi+\alpha_j)} - W_1 e^{i(\theta+\beta_j)} = 0 \quad (1)$$

For right side dyad:

$$U_1 e^{i\sigma} + S_1 e^{i\psi} + P_{j1} e^{i\beta_j} - S_1 e^{i(\psi+\alpha_j)} - U_1 e^{i(\psi+\gamma_j)} = 0 \quad (2)$$

Now for  $j=4$ , four prescribed coupler positions, three standard form equations are formed. The displacement from position 1 to 2, 1 to 3 and 1 to 4 can be presented by equations (3, 4, 5) respectively. These three equations give five unknowns ( $W, Z, \beta_2, \beta_3, \beta_4$ ).

$$W_1 e^{i\theta} (e^{i\beta_2} - 1) + Z_1 e^{i\Phi} (e^{i\alpha_2} - 1) = P_{21} e^{i\beta_2} \quad (3)$$

$$W_1 e^{i\theta} (e^{i\beta_3} - 1) + Z_1 e^{i\Phi} (e^{i\alpha_3} - 1) = P_{31} e^{i\beta_3} \quad (4)$$

$$W_1 e^{i\theta} (e^{i\beta_4} - 1) + Z_1 e^{i\Phi} (e^{i\alpha_4} - 1) = P_{41} e^{i\beta_4} \quad (5)$$

For a range value of  $\beta_2$ , a locus of moving and fixed pivots can be obtained where  $k = -z$  (moving pivot) and  $m = k - w$  (fixed pivot) as shown in fig. 1. These curves of moving and fixed pivots known as *circle* and *center point curves* respectively or *Burmester curves*. Fig. 2 embellish a four-bar mechanism for which Burmester curve is produced. Every point on the circle point curve represents a moving point of a mechanism and each point on the center point curve is a fixed point of that same mechanism.

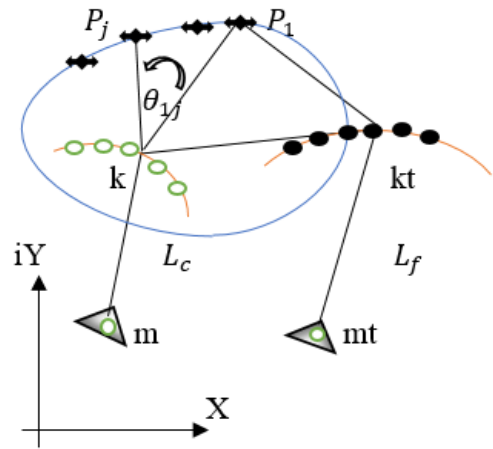

**Fig 2:** Burmester curve for a planar four-bar mechanism

### 3. Filemon's construction

Synthesized mechanism will attain all the prescribed precision positions but it is not necessary that they will follow the following conditions:

- Without disassembling or any change in its original configuration, the synthesized mechanism will follow the prescribed rigid-body output parameter (Branch defect).
- Synthesized mechanism will attain or approximate the prescribed rigid-body guidance in purposive order (Order defect).

So, to remove the possibility of defects in mechanism Filemon's construction is applied on the generated Burmester curve. Filemon constructed a wedge-shaped region by his method of construction. If the crank of a selected mechanism having its moving pivot out of that region then the motion generator will attain all the prescribed precision positions without any non-branching and disordering solution. Before the construction it is assumed that the follower link has already been selected. The fixed and moving pivot of a mechanism are represented by  $mt$  and  $kt_0$  respectively. Where  $mt = -s$  and  $kt_0 = -s - U$ . Now the follower link will sweep a planar wedge-shaped region and the extreme positions of  $kt$  relative to  $mt$  are computed as:

$$mt_{0j} = [M_j] mt_0 \quad (6)$$

And

$$[M_j] = \begin{bmatrix} 1 & 0 & 0 \\ 0 & 1 & 0 \\ 0 & 0 & 1 \end{bmatrix} \begin{bmatrix} \cos\alpha_j & -\sin\alpha_j & P_{j1x} \\ \sin\alpha_j & \cos\alpha_j & P_{j1y} \\ 0 & 0 & 1 \end{bmatrix}^{-1} = 2, 3, \dots \quad (7)$$

And

$$mt_0 = (mt_{0x}, mt_{0y}, 1)^T$$

Fig. 3(a) shows Filemon’s construction for a planar four-bar mechanism whose follower link length is  $U$ . Fig. 3(b) shows that the moving pivot of crank of synthesized mechanism is outside the wedge-shaped region that ensures complete rotation of crank.

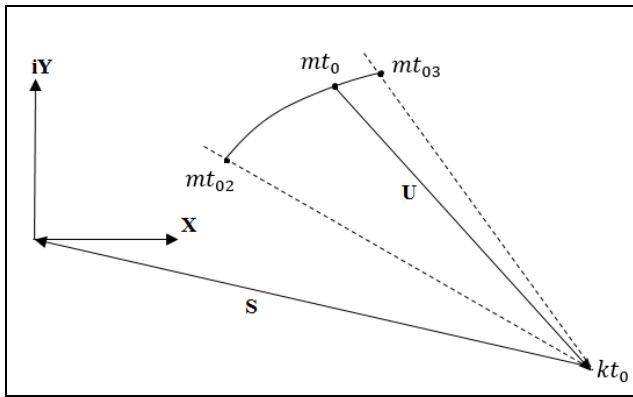

Fig 3(a): Wedge-shaped region for a four-bar mechanism

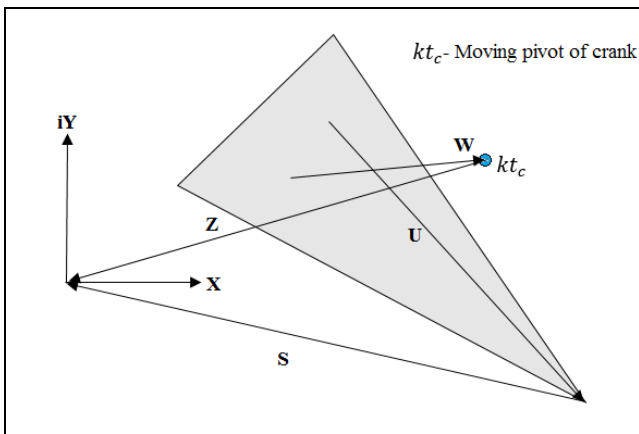

Fig 3(b): A four-bar mechanism is having crank moving pivot outside the wedge region.

**4. Compactness algorithm**

The algorithm which is produced in this work contains all the constraints like Grashof condition for double rocker type mechanism as well as for crank rocker type mechanism. Second constraint is optimal transmission angle, that is maximum and minimum transmission angles for designed mechanism should be in the range  $140^\circ$  to  $35^\circ$ . Third constraint is minimum perimeter condition. A fourth constraint is applied to remove defects in the synthesized mechanism i.e. Filemon’s construction. These conditions are applied to the possible mechanism solutions in the given Burmester curve. A block diagram (fig.4) presented in the work of Peter J. martin [1] is modified in this work by introducing the Filemon’s construction. A different selection methodology for mechanism solutions from the Burmester curve is also applied in this algorithm.

In this work, this algorithm is named as *Compactness algorithm*, because of final output mechanism is a compact mechanism among all possible solutions from the fixed and moving pivot curve. Here in this algorithm a procedure is followed to get a synthesized mechanism out of all possible

mechanism. To obtain the final results, four-point precision method is used. After the selection of mechanisms calculate all the link length of each mechanism. This is done by the calculation of distances between different pair of fixed and moving points. In Block B2 Filemon’s construction is applied on the generated Burmester curve for finding the correct number of fixed and moving pivots. Here correct number means only the points for which the synthesized mechanism is defect free. According to Block B3 and B4 calculate maximum, minimum, and the range of transmission angle for the same range of crank rotation for which Burmester curve was generated.

Now coming to the Block B5 according to that the type of mechanism is selected. Grashof condition (table 3.1) is applied in this block of the algorithm. Here in this work two types of mechanism (crank rocker and double rocker mechanism) are designed.

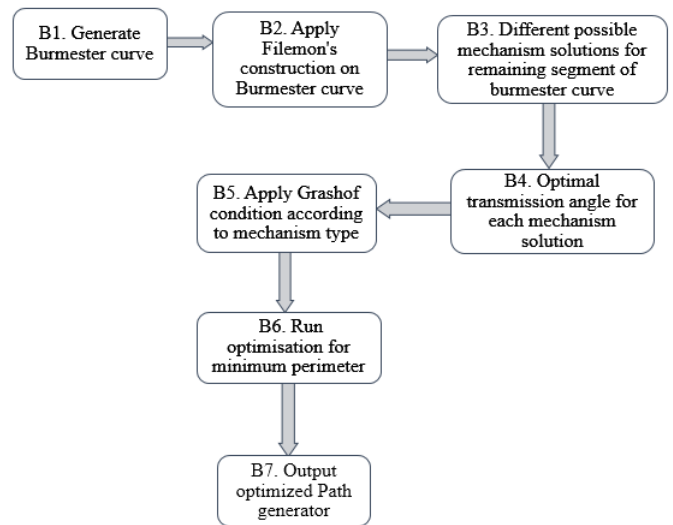

Fig 4: Flow chart for perimeter algorithm

**5. Ameliorated Grashof Path Generator for Landing Gear**

For the justification of the algorithm a common example of landing gear of aero plane is taken [11]. A planar four bar synthesized mechanism, to guide the landing gear through the four precision points, is generated by path generator. This motion generator is a Grashof crank rocker type. The prescribed precision positions are shown in the table 1 [11]. Initially Burmester curve is produced for the range  $[120^\circ \text{ to } 280^\circ]$  of  $\beta_2$  (crank rotation). Fig. 5 shows three precision positions and position parameters for the landing gear. Fig. 6 shows the fixed and moving curves generated for that range of rotation of crank which gives the availability of number of mechanism solutions.

Table 1: Landing gear Precision Position Parameters and Dyad Displacement Angles

Precision position	$p_j$	$\alpha_j$ {deg.}
1	0,0	-
2	0.292, 0.734	-51.7124
3	0.251, 1.227	-66.9732
4	0.299, 1.461	-84.9734

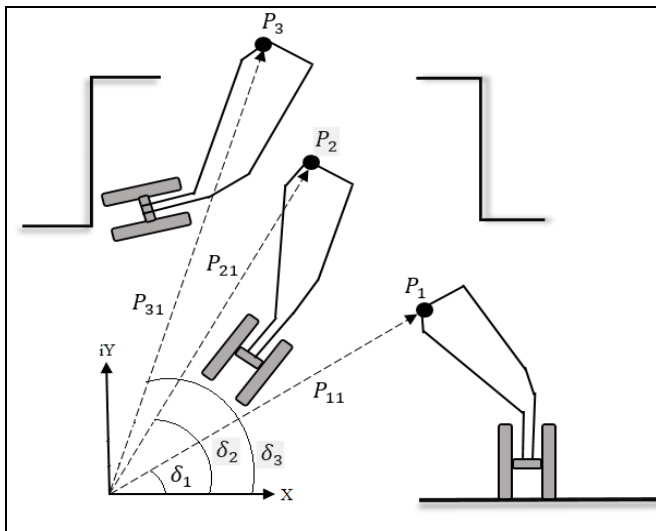

**Fig 5:** Three positions and position parameters for aero plane landing gear

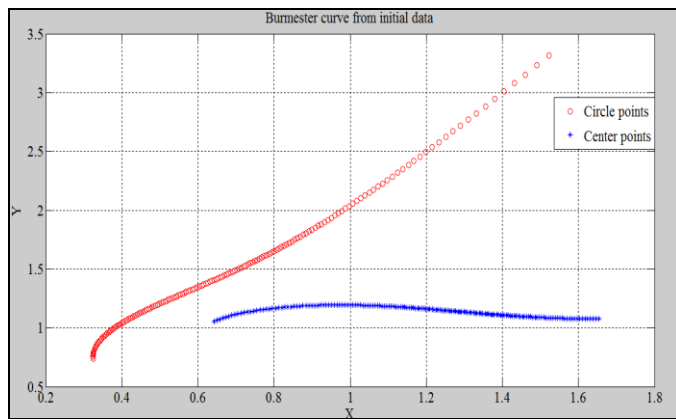

**Fig 6:** Fixed (center) and moving (circle) pivot curve from initial data for landing gear

Now according to perimeter algorithm above described apply Filemon's construction on this generated Burmester curve (fig. 7) and get a new set of fixed and moving pivots. As shown in fig. the wedge-shaped region is produced for a random selection of driving link. According to it the moving pivot should be outside the wedge-shaped region. Now corresponding to the remaining segment of moving pivot curve there is fixed pivot curve that is available to generate mechanism solutions and further process depend on these curves. The work is to determine the different positions of coupler point P of the generated mechanism when crank rotate.

Now the co-ordinates of point P will be (fig. 7)

$$P_x = A_x + r_p \cos(\theta_3 + \delta);$$

$$P_y = A_y + r_p \sin(\theta_3 + \delta)$$

$$A_x = O_{1x} + a \cos \theta_2; A_y = O_{1y} + a \sin \theta_2$$

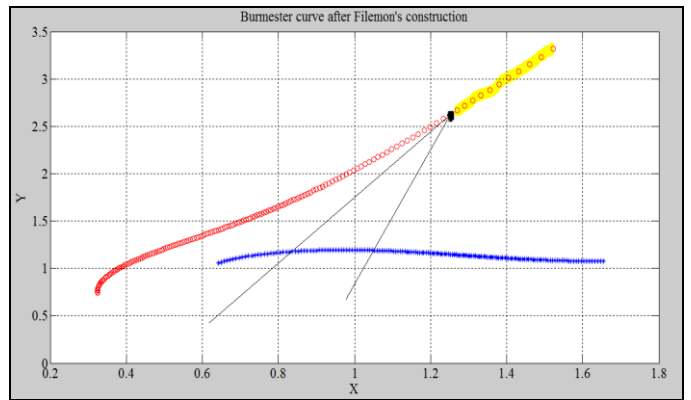

**Fig 7:** Burmester curve after Filemon's construction

Now, from the generated Burmester curve without Filemon's construction, fig. 8 shows that coupler curve is not passing through point  $P_1$  and  $P_4$ . After this perimeter algorithm run to its final block B7 and we get a synthesized path generator whose parameters are shown in table 2.

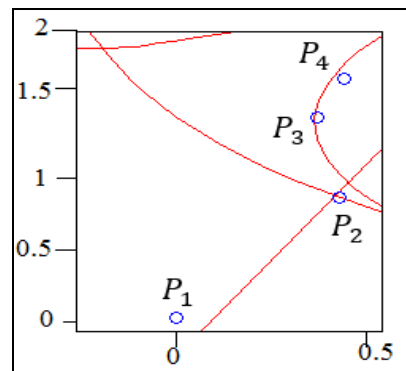

**Fig 8:** Coupler curve generated from path generator produced from Burmester curve without Filemon's construction

**Table 2:** Synthesized four-bar linkage for landing gear

Parameters for the synthesized selected mechanism	
Length of ground link (a)	0.0217
Length of crank (b)	0.6270
Length of coupler (c)	0.0401
Length of follower (d)	0.6454

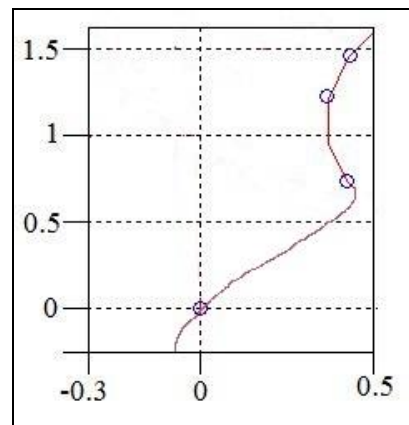

**Fig 9:** shows the coupler curve for synthesized four-bar mechanism which is passing through all prescribed points.

To justify the condition of rotatability, the transmission angle variation for the same range of  $\beta_2 [180^\circ \text{ to } 280^\circ]$  is checked whether it is crossing the extreme limits (see figure 10).

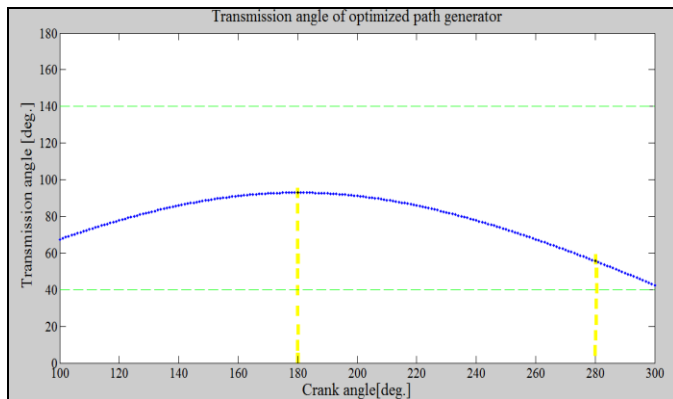

**Fig 10:** Transmission angle variation w.r.t crank rotation for the synthesized path generator

## 6 Conclusion

To attain the number of predefined coupler points, there are infinite number of Grash of mechanism solutions present. After applying some conditions, out of these solutions a synthesized path generator is produced in which driving link is having full rotation and transmission angles produced in the feasible range and this work is done through Burmester curve which is produced numerically by an algorithm.

Since MATLAB is giving an ability to ease of use so, algorithm is codified on this interface. The two examples (Landing gear of an aero plane and prosthetic knee joint four-bar mechanism) are justifying the results and use of this algorithm on different Grash of mechanism.

## 7. References

1. Peter J. Martin, Kevin Russell, Raj S. Sodhi, On mechanism design optimization for motion generation, *Mechanism and Machine Theory*. 2007; 42(3):1251-1263.
2. Erdman AG. Three and Four Precision Point Kinematic Synthesis of Planar Linkages, *Mechanism and Machine Theory*. 1981; 16(3):227-245.
3. Sancibrian R, Garcia P, Mader F, Fernandez A. (In Press), A General Procedure Based on Exact Gradient Determination in Dimensional Synthesis of Planar Mechanisms," *Mechanism and Machine Theory*
4. Daniel A Brake, Jonathan D Hauensteiny, Andrew P Murrayz, David H Myszkax2. the complete solution of Alt-Burmester synthesis problems for four-bar linkages pp, 2015
5. Lebedev PA. Vector Method for the Synthesis of Mechanisms, *Mechanism and Machine Theory*. 2003; 38(3):265-276.
6. Khare, AK Dave RK. Optimizing four bar crank rocker mechanism, *Mechanism and Machine Theory*. 1979; 14(5):319-325.
7. Chiang CH. Synthesis of Four-bar Function Generators by means of Equations of Three Relative Poles. Finitely Separated Positions, *Mechanism and Machine Theory*. 1975; 10(1).