

## Power factor correction of a three-phase induction motor using SAPF

Parshant Tyagi

Assistant Professor, Department of Electrical Engineering, MITRC, Alwar, Rajasthan, India

### Abstract

This paper describes the feasibility of unity power factor operation for three-phase induction motor subjected to variable loads. In this paper a shunt active power filter is used to provide such operation. The principle of operation is introduced. The two-loop control strategy is used to analyze. From simulation results it is clear that, under all loading conditions, the power factor is achieved unity automatically. Furthermore, the supply current can be obtained sinusoidal. A system based on microcontroller has been tested in the lab to confirm the analysis. The experimental results show that this method to improve power factor of motor is feasible.

**Keywords:** power factor, three phase induction motor, active power filter

### 1. Introduction

Induction motors are commonly used in domestic, commercial and industrial applications. The power factor of induction motors is usually low and depends upon the load. If the motor is subjected to a fixed load, the power factor of the motor can be improved by a single fixed capacitor connected across the terminals of the motor. For variable load conditions, the power factor can be improved by using switched capacitors. But such a scheme provides capacitance variation in discrete steps and there is over compensation occurs therefore this method is not optimum. A Thyristor switched capacitor (TSC) type of static compensator is used to improve power factor of motor<sup>[1]</sup>. It can be used to improve the power factor of motors, but the cubage and weight of the system is too large to be implied in the small motor system.

This paper describes a method in which the power factor of induction motors can be improved by using a shunt active power filter. In this system a three-phase pulse width modulated (PWM) voltage source inverter connected to independently controlled dc bus. The size of the system is small. Therefore it can be integrated with motors and provides a unity power factor operation under varying load condition. The model of the system is given in this paper and computer simulation is completed. Simulation results indicate that this kind of system can operate with unity power factor of three phase induction motor.

### 2. Power factor Improvement by using capacitor bank

The power factor improvement method employing a capacitor bank is shown in fig.1

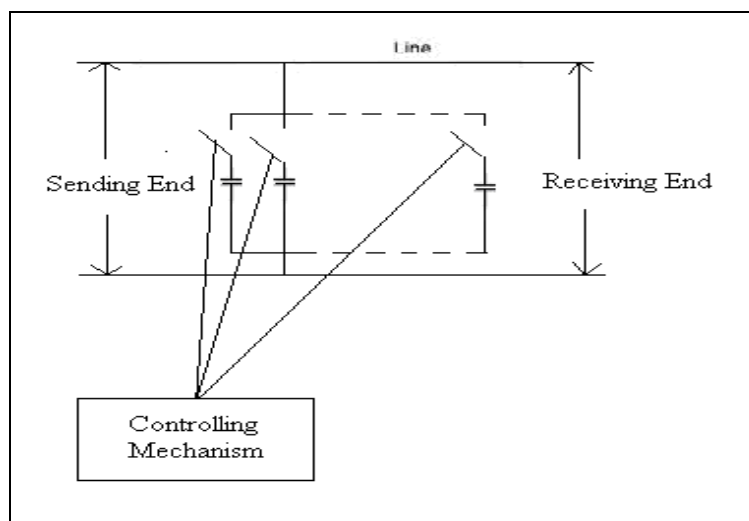

Fig 1: pf improvement using capacitor bank

In this method a program is written to add capacitor in steps according to the reactive power requirement.

**3. Power factor Improvement by using Thyristor Switched Capacitor (TSC):** The power factor improvement method

employing a “Thyristor Switched Capacitor” is illustrated in fig.2

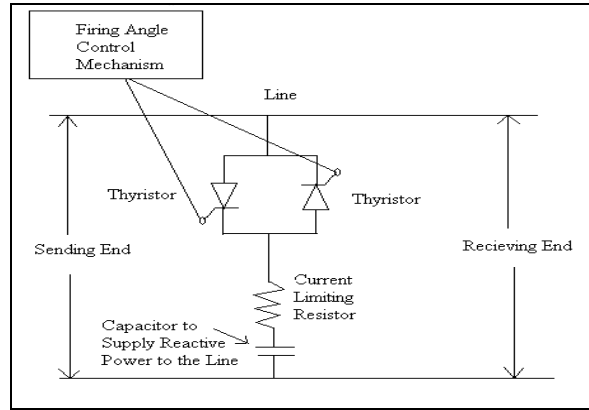

Fig 2: pf improvement using TSC

In this control method the capacitor energy supply can be controlled by thyristor. When the firing angle of the Thyristor is varied, then voltage supplied by the capacitor will be changed so that the reactive power supplied by the capacitor will also be varied. A resistance is connected in series with the capacitor to limit the current flowing through the capacitor. The main purpose of resistor is to protect the capacitor from damages due to the high current.

load current are themselves the source current, which causes degradation in power factor and introduces harmonic distortion. When the SAPF block is operating it injects currents  $i_c$  current equal in magnitude but in phase opposition to harmonic current in each of the lines. This current compensates the harmonic distortion and makes the source current balanced sinusoidal while the load current is nonlinear.

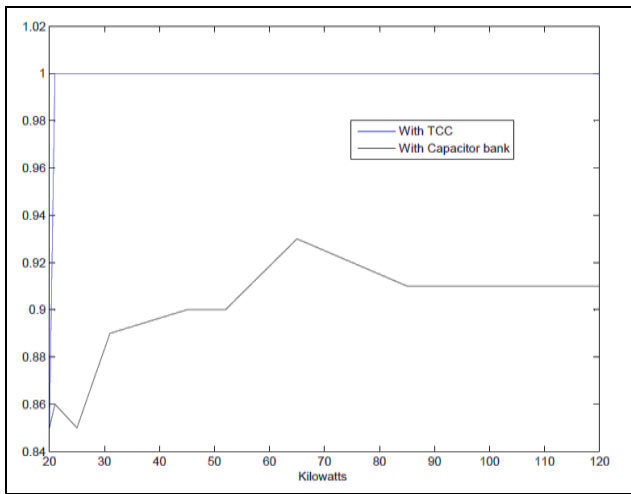

Fig 3: Power factor comparison graph

#### 4. Power factor improvement by using shunt active power filter

It is a device used in parallel with the load. It compensates the current harmonics in the line. It also helps in reactive power compensation in the line. Due to injection of current harmonics it improving the power factor and increasing the efficiency of system and also reduces the losses caused by the harmonics [2].

##### Basic working principle

The schematic diagram of shunt active power filter shown in fig.4. The  $i_s$  is source current,  $i_L$  is load current,  $i_c$  is compensating current. The source is a balanced voltage source where the phase voltages are transferred source to nonlinear loads. When the SAPF block is not operating the nonlinear

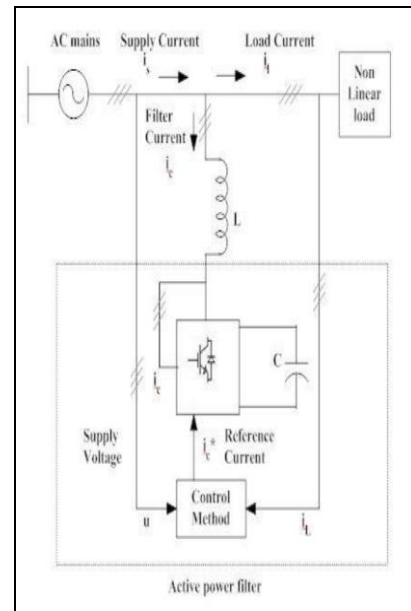

Fig 4: Schematic diagram of shunt connected active power filter

This SAPF block is basically divided into two parts. The first part is a control block and second part is converter either VSI with capacitor source or CSI with inductive source. The control block is done necessary computations and operations to generate the compensation current reference [3, 4].

Control Methods used in Active Power Filter are:

- synchronous detection method
- Synchronous Reference Current Theory (d-q Theory).
- Instantaneous Power Theory (P-Q Theory)
- Notch filter method

Above all these methods are used in the development of

Active Power Filter [4]. In this paper we only discuss only two control methods of Active Power Filter.

**5. Digital control of SAPF Based on P-Q Theory**

The instantaneous reactive power theory is the most widely used as a control strategy for the APF. It is mainly applied to compensation equipment in parallel connection. This theory is based on a Clarke coordinate transformation from the phase co-ordinates (see Fig.).

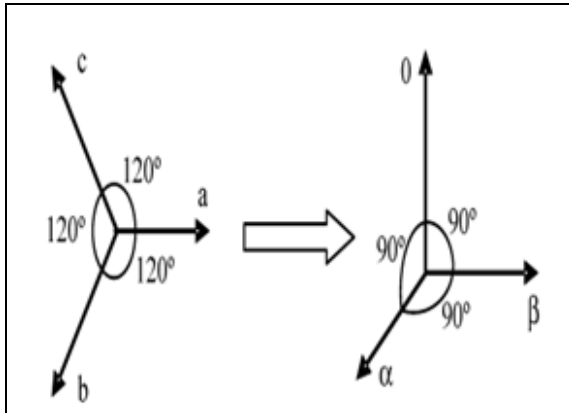

**Fig 5:** Transformation from the phase reference system (ab c) to the (0αβ) system [5].

It is described a method of calculating the instantaneous power components from some transformed values of three-phase voltages and currents. The only desirable quantity among all the power components obtained through the p-q theory is real power (p) because it corresponds to the energy transferred from the supply to the load. To compensate all the other quantities SAPF is used. This theory represented an easy way to compensate real power by delivering it from the power source to the active filter through α-β coordinates, so that the active filter is supply this power to the load through the 0 coordinates in a balanced way [3].

The p-q theory calculations are done in the shunt active power filter controller block [6].

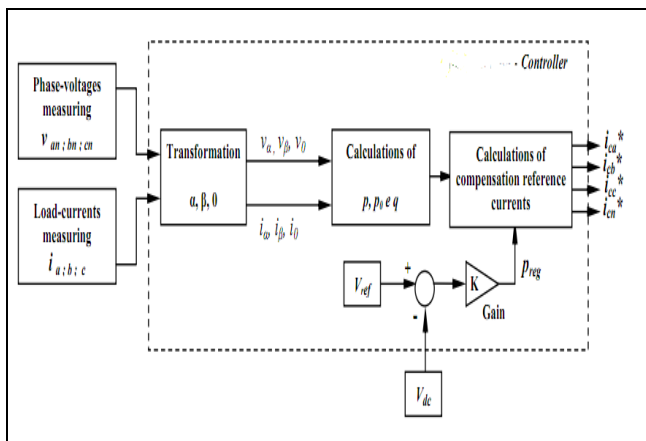

**Fig 6:** Calculations of the p-q theory

The controller allows, in a organized way, according to the received information it verify the needing of compensation

currents by the active filter. The controller receives the information of phase voltages, load currents and DC voltage, and based on its control algorithm, proceeds to the calculations of the p-q theory values, generating, or not, the necessary reference compensation currents, which are injected in the power system by the inverter block.

$$\begin{bmatrix} i_{ca}^* \\ i_{cb}^* \\ i_{cc}^* \end{bmatrix} = \sqrt{\frac{2}{3}} \begin{bmatrix} 1/\sqrt{2} & 1 & 0 \\ 1/\sqrt{2} & -1/2 & \sqrt{3}/2 \\ 1/\sqrt{2} & -1/2 & -\sqrt{3}/2 \end{bmatrix} \cdot \begin{bmatrix} i_{c0}^* \\ i_{c\alpha}^* \\ i_{c\beta}^* \end{bmatrix}$$

When the above currents are fed to the VSI it generates the exact same of these currents but in magnitude equal to the original line currents. These compensated currents are injected to the system to obtain in-phase sinusoidal source currents with the line voltages that improved the power factor in the system [3].

**6. Control of SAPF system using Synchronous Detection Method (SDM):**

In the SDM, it is assumed that the three-phase main currents are balanced after compensation, and it tries to determine that required amplitude of the main currents. The instantaneous nonlinear load currents and corresponding phase voltages are measured from the lines and real power P (t) is calculated from them Then the average value Pdc is determined by applying P (t) to a low pass filter. Thus, the real power is split into the three phases P<sub>a</sub>, P<sub>b</sub>, P<sub>c</sub>

The compensations current references are

$$\begin{aligned} i_{ca}^* &= i_{sa} - i_a \\ i_{cb}^* &= i_{sb} - i_b \\ i_{cd}^* &= i_{sc} - i_c \end{aligned}$$

The compensation current references  $i_{ca}^*$ ,  $i_{cb}^*$  and  $i_{cc}^*$  are given to the VSI which supplies the exact same of these currents  $I_{ca}$ ,  $I_{cb}$  and  $I_{cc}$  to the line. Since the PWM VSI is assumed to be instantaneous to track the compensation currents, it is work as a current amplifier with unity gain [3].

Faster power factor improvement is a basic requirement for industrial and consumer equipment's and SAPF offers better performance than other compensation methods. It improves power factor by significantly reducing the harmonic components in currents. The digital control of SAPF based on p-q theory provides faster power factor improvement than SDM technique. In summing, digital control of SAPF should be the preferred choice for power factor improvement.

**7. Conclusions**

In this paper a power factor compensation system for three-phase induction motor has been presented. The proposed system has employed an active power filter to be connected to the supply with induction motor directly. The performance of two-loop control strategy is analyzed through transfer function. The system is modeled and simulated to provide theoretical reference. The experimental system based on microcomputer 80C552 is built and tested. Experimental results show that motor will operate with unity power factor,

at the same time, the ac supply provides only active current and transmission loss of electrical wire is decreased.

## 8. References

1. IEEE Std. 519-1992, IEEE Recommended Practices and Requirements for Harmonic Control in Electrical Power Systems, New York, NY: IEEE.
2. International Journal of Scientific Engineering and Research (IJSER), 2013; 1(3), ISSN (Online): 2347-3878
3. Md. Ashfanoo Kabir, Upal Mahbub, Synchronous Detection and Digital control of Shunt Active Power Filter in Power Quality Improvement, IEEE Press.
4. International Journal of Engineering Trends and Technology (IJETT) - Importance of Active Filters for Improvement of Power Quality, 2013; 4(4).
5. Salmerón P, Litrán SP. Improvement of the Electric Power Quality Using Series Active and Shunt Passive Filters, IEEE transactions on power delivery, 2010; 25(2).
6. Emílio F. Couto, Júlio S. Martins, João L. Afonso, Simulation Results of a Shunt Active Power Filter with Control Based on p-q Theory.