



Developed subband adaptive filter construction - using multirate signal processing transform

Er. Khet Singh

Assistant Professor, Department of Electronics and Communication, Vedant College of Engineering & Technology, Kota, Rajasthan, India

Abstract

The multirate signal processing subband techniques have been recently developed for adaptive filters, since some of the applications such as acoustic echo cancellation and wideband active noise control need adaptive filters with hundreds of taps, which result in high computational complexity and low convergence rate. By the use of Subband adaptive algorithms, the computational complexity may be reduced along with convergence rate; however, a delay is introduced in the signal path. To remove the delay, the delayless subband adaptive filter architecture open loop structures have been introduced. This paper presents a new open loop delayless subband adaptive filter structure with critical sampling, where the performance concerning the mean square error of the subband adaptive algorithm, caused due to the aliasing existing in the subband structure, is superior to the results obtained up to now for open loop delayless structures. In applications like echo cancellation and speech enhancement, where there is need to track continuously, adaptive filtering is usually used. Long adaptive filters gives problems like low convergence and high complexity. Subband adaptive filtering has been introduced to overcome these problems. The filter banks used in subband adaptive filtering introduce large delays. In order to compensate for the delays, delayless subband adaptive filtering is introduced. Delayless subband adaptive filtering is used in both open loop and closed loop configuration, where the subband filters are transformed to a fullband filter using a weight.

Keywords: convergence, least mean square, inter symbol interference, critically, subband sampled

1. Introduction

Subband adaptive filtering is rapidly becoming one of the most effective techniques for reducing computational complexity and improving the convergence rate of algorithms in adaptive signal processing applications. Discuss the basic principles that underlie the design and implementation of subband adaptive filters. Comprehensive coverage of recent

developments, such as multiband tap-weight adaptation, delayless architectures, and filter-bank design methods for reducing band-edge effects are included. Several analysis techniques and complexity evaluation are also introduced in this report to provide better understanding of subband adaptive filtering.

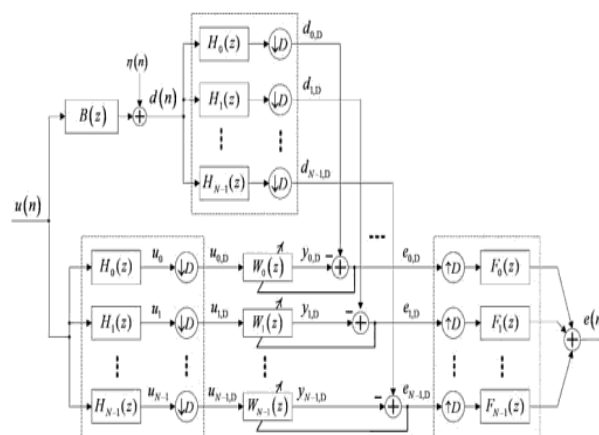

Fig 1: Conventional block diagram of sub band adaptive filter

Adaptive filtering is a widespread technique in many applications. For acoustic echo cancellation (AEC) hands-free telephony, very large adaptive filters are used in a system identification on text, whereas in digital communications, adaptive filters perform the channel. Distortion equalization. The present need for increased throughput in new systems also

results in an increase of the equalizer length. In these two areas, there is a demand for efficient and low complexity algorithms.

2. Adaptive subband structure and adaptation algorithm

We study the convergence analysis of the multirate. The

structure consists of two analysis banks, which split the input and desired signals into L bands each. The subband signals are modified by adaptive filters, after being decimated by a factor M, and the coefficients of each subband filter are adapted independently using the individual error signal. In the last equation $D_i(m)$ is the desired signal in subband and $Y_i(m)$ the signal in the output of each adaptive subfilter,

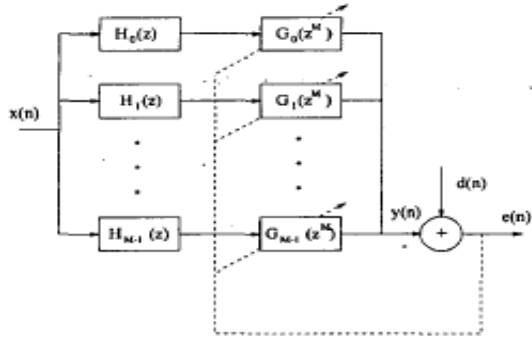

Fig 2: Adaptive subband structure with sparse

In system identification scenario, the linear approximation of the system modelled by its impulse response, is estimated in real time by gradient type Least Mean Square (LMS) or Recursive Least Squares (RLS) algorithms. In recent applications like acoustic echo cancellation, the order of the impulse response to be estimated is very high, and these traditional approaches are inefficient and real time implementation becomes difficult. Alternatively, the system is modelled by a set of shorter adaptive filters operating in parallel on sub sampled signals. This approach, referred to as subband adaptive filtering, is expected to reduce not only the computational complexity but also to improve the convergence rate of the adaptive algorithm. But in practice, different subband adaptive algorithms have to be used to enhance the performance with respect to complexity, convergence rate and processing delay. This quantity can be obtained recursively by the equation:

$$P_i(m+1) = \beta P_i(m) + (1 - \beta) X_i^2(m)$$

For $0 < \beta < 1$.

3. Subband adaptive filtering design

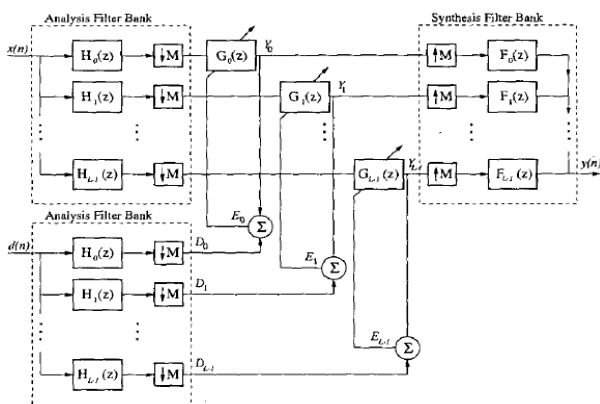

Fig 3: Subband adaptive filtering structure

Adaptive filtering in subbands has been extensively

investigated in order to reduce the computational complexity of high order adaptive FIR filters. It has been mostly applied to echo cancellers for audio teleconferencing, where adaptive FIR filters of very large lengths (1000-4000 coefficients) are used. A general j sub band adaptive structure is shown in Fig. 2 Observe that each adaptive subband filter is adapted independently of the others, by using the individual error of the corresponding sub band. The use of critical sub sampling ($L = M$) in the structure of Fig. 1 results in undesirable aliasing effects due to the channel modifications introduced by the adaptive sub filters. In order to avoid such alias problems, the reduction of the sampling rate of the filtered signals by a factor smaller than the critical sub sampling factor (i.e., $L < M$) is frequently used in this paper.

4. Scope of the paper

The convergence behavior of the open loop and closed loop configurations of the delayless subband adaptive filters is studied. It is shown that the Subband to-fullband transform greatly affects the performance in terms of the fullband mean square error for the open loop configuration and in terms of the convergence speed for the closed loop configuration. It is shown that based on the results for the closed loop case, a transform with optimal convergence performance can be derived. A novel delayless subband adaptive filter is presented, which employs polyphase adaptive filters. The convergence and complexity analysis in this report give the following results the conventional open loop delayless subband adaptive filter has limited performance in terms of the fullband mean square error. However, the performance may be sufficient for the application at hand and the convergence speed may be high.

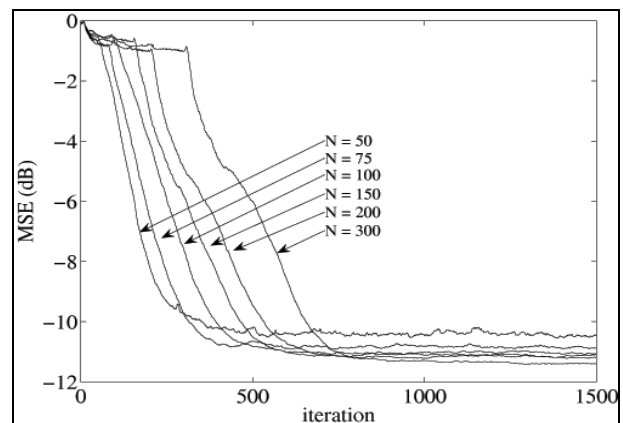

Fig 4: convergence rate between WSAF and FBLMS

5. The adaptive subband structure and adaptation algorithm

We study the convergence analysis of the multirate. The structure consists of two analysis banks, which split the input and desired signals into L bands each. The subband signals are modified by adaptive filters, after being decimated by a factor M, and the coefficients of each subband filter are adapted independently using the individual error signal. In the last equation $D_i(m)$ is the desired signal in subband and $Y_i(m)$ the signal in the output of each adaptive sub filter. This quantity can be obtained recursively by the equation.

In system identification scenario, the linear approximation of the system modeled by its impulse response is estimated in real time by gradient type Least Mean Square (LMS) or Recursive Least Squares (RLS) algorithms. In recent applications like acoustic echo cancellation, the order of the impulse response to be estimated is very high, and these traditional approaches are inefficient and real time implementation becomes difficult. Alternatively, the system is modelled by a set of shorter adaptive filters operating in parallel on sub sampled signals.

6. Simulated and Measured Results

Experiments open loop delayless filter were performed with the fullband normalized LMS, and with the delayless subband structure of Fig. 11 using perfect reconstruction cosine modulated filter banks and $M = 5, 10, 12,$ and 13 subbands. The step-sizes were selected such that the best convergence rate was obtained in each case. Figure 11 presents the MSE evolutions. The new delayless subband structure presents a better convergence rate than the LMS algorithm, due to the power normalization of the step-sizes. The subband algorithm of [converges to the minimum MSE of the fullband LMS; however, it requires more multiplications than the proposed delayless algorithm.

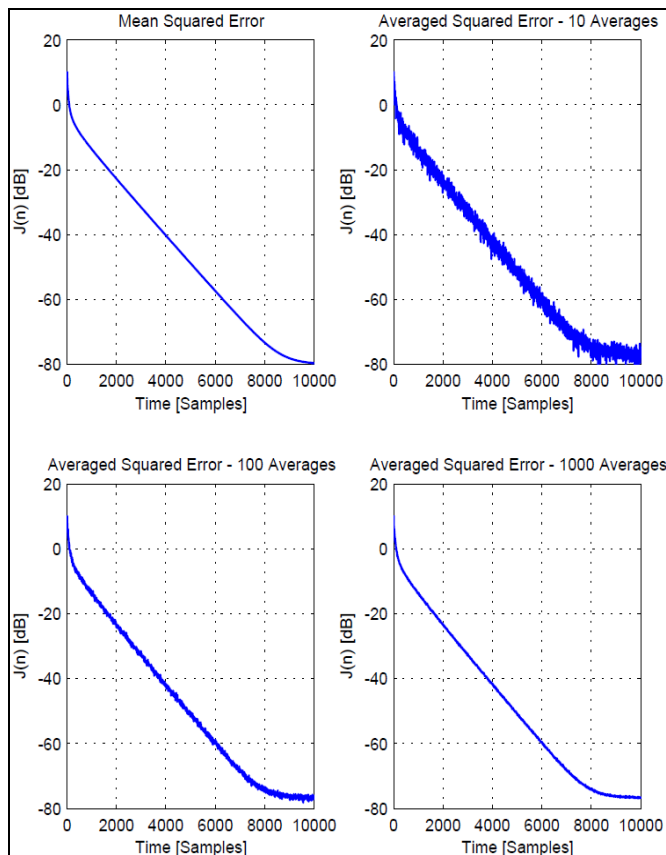

Fig 5: Magnitude of the coefficient errors $|\Delta f_i(n)|$ for the LMS adaptive filter

7. Conclusions

The conventional closed loop delayless subband adaptive filter may reach the same mean square error as the LMS algorithm but may have limited performance in terms of the convergence

speed, due to a non-optimal transform. A theoretical expression for the optimal transform is derived. Sub-optimal transforms may be derived using a-priori knowledge about the input signal. An open loop delayless polyphase subband adaptive filter can converge with high speed, using only few subbands. For a certain scenario it is shown that an adaptive filter with approximately 1000 taps can be adapted using 16 subbands.

8. References

1. Gilloire, Vetterli M. Adaptive Filtering in Subbands with Critical Sampling: Analysis, Experimentand Application to Acoustic Echo Cancellation, *IEEE Trans. Signal Processing*. 1992; 40(8):1862-1875.
2. Petraglia MR, Mitra SK. Performance Analysis of Adaptive Filter Structures based on Subband Decomposition, in *Proc. IEEE Int. Symp. Circ. Syst.*, Chicago, IL, 1993, 60-63.
3. Petraglia MR, Alves RG, Diniz PSR. New Structures for Adaptive in Subbands with Critical Sampling, *IEEE Trans. on Signal Processing*. 2000; 48(12):3316-3327.
4. Morgan R, Thi JC. A Delayless Subband Adaptive Filter Architecture, *IEEE Trans. on Signal Processing*.
5. Merched R, Diniz PSR, Petraglia MR. A New Delayless Subband Adaptive Filter Structure, *IEEE Trans. On. Signal Processing*. 1999; 47(6):1580-1591.
6. Pradhan SS, Reddy VU. A New Approach to Subband Adaptive Filtering,," *IEEE Trans. on Signal Processing*.
7. Haykin S. *Adaptive Filter Theory*, 3rd ed., Prentice-Hall, Englewood Cliffs, New Jersey, 1996. G. Strang and T. Nguyen, *Wavelets and Filter Banks*. Wellesley - Cambridge Press, 1996.
8. Mariane R, Petraglia Rogerio G, Alves Swamy MNS. A New open loop delayless subband adaptive filter, 2002.
9. Gilloire, Vetterli M. Adpative filtering in subbands with critical sampling: Analysis, experiments, and application to acoustic echo cancellation, *IEEE Trans. Signal Process.* 1992; 40(8):1862-1875.
10. Lars-Olof Larson, Jan Mark de Haan. Ingvar Claesson New subband weight transform delayless subband adaptive filter, 2000.
11. de Haan JM, Larson LO, Claesson I. Filter Bank Design for Delayless Subband Adaptive Filtering.