



## Parameter study for waste heat recovery system implemented in two stroke petrol engine

Dr. Ashish Mathew

Professor, Department of Mechanical Engineering, Vedant College of Engineering & Technology, Bundi, Rajasthan, India

### Abstract

The more and more worldwide downside concerning speedy economy development and a relative shortage of energy, the interior combustion engine exhaust waste heat and environmental pollution has been a lot of stressed heavily recently. Out of the overall heat equipped to the engine within the sort of fuel, around, thirty to four-hundredth is born-again into helpful mechanical work; the remaining heat is expelled to the atmosphere through exhaust gases and engine cooling systems, leading to entropy rise and high environmental pollution, therefore it's needed to use waste heat into helpful work. The recovery and utilization of waste heat not solely conserves fuel (fossil fuel) however additionally reduces the number of waste heat and greenhouse gases damped to atmosphere. The study shows the supply and risk of waste heat from combustion engine, additionally describe loss of exhaust gas energy of an indoor combustion engine. Many ways to recover the waste heat from combustion engine and performance and emissions of the interior combustion engine. Waste heat recovery system is that the best thanks to recover waste heat and saving the fuel.

**Keywords:** efficiency, emission, waste heat from i. c. engine, waste heat recovery system for i. c. engine

### Introduction

Recent trend about the best ways of using the deployable sources of energy in to useful work in order to reduce the rate of consumption of fossil fuel as well as pollution. Out of all the available sources, the internal combustion engines are the major consumer of fossil fuel around the globe. Out of the total heat supplied to the engine in the form of fuel, approximately, 30 to 40% is converted into useful mechanical work. The remaining heat is expelled to the environment through exhaust gases and engine cooling systems, resulting in to entropy rise and serious environmental pollution, so it is required to utilized waste heat into useful work. The recovery and utilization of waste heat not only conserves fuel, usually fossil fuel but also reduces the amount of waste heat and greenhouse gases damped to environment. It is imperative that serious and concrete effort should be launched for conserving this energy through exhaust heat recovery techniques. Such a waste heat recovery would ultimately reduce the overall energy requirement and also the impact on global warming. The Internal Combustion Engine has been a primary power source for automobiles and automotives over the past century. Presently, high fuel costs and concerns about foreign oil dependence have resulted in increasingly complex engine designs to decrease fuel consumption. For example, engine manufacturers have implemented techniques such as enhanced fuel-air mixing, turbo-charging, and variable valve timing in order to increase thermal efficiency. However, around 60-70% of the fuel energy is still lost as waste heat through the coolant or the exhaust. Moreover, increasingly stringent emissions regulations are causing engine manufacturers to limit combustion temperatures and pressures lowering potential efficiency gains<sup>[1]</sup>. As the most widely used source of primary power for machinery critical to the transportation,

construction and agricultural sectors, engine has consumed more than 60% of fossil oil. On the other hand, legislation of exhaust emission levels has focused on carbon monoxide (CO), hydrocarbons (HC), nitrogen oxides (NOx), and particulate matter (PM). Energy conservation on engine is one of best ways to deal with these problems since it can improve the energy utilization efficiency of engine and reduces emissions<sup>[2]</sup>. Given the importance of increasing energy conversion efficiency for reducing both the fuel consumption and emissions of engine, scientists and engineers have done lots of successful research aimed to improve engine thermal efficiency, including supercharge, lean mixture combustion, etc. However, in all the energy saving technologies studied. Engine exhaust heat recovery is considered to be one of the most effective. Many researchers recognize that Waste Heat Recovery from engine exhaust has the potential to decrease fuel consumption without increasing emissions, and recent technological advancements have made these systems viable and cost effective<sup>[3]</sup>. This paper gives a comprehensive review of the waste heat from internal combustion engine, waste heat recovery system and methods of waste heat recovery system.

### 2. Heat recovery possibility and availability from i.c. engine

Waste heat is heat, that is generated during a method by means of fuel combustion or chemical change, and so "dumped" into the surroundings although it may still be reused for a few helpful and economic purpose. This heat depends partly on the temperature of the waste heat gases and mass flow of exhaust gas. Waste heat losses arise each from instrumentation inefficiencies and from thermodynamical limitations on instrumentation and processes for instance, think about burning engine just about thirty to four-hundredth

is born-again into helpful mechanical work. The remaining heat is expelled to the surroundings through exhaust gases and engine cooling systems [4]. It means that just about sixty to seventieth energy losses as a waste heat through exhaust (30% as engine cooling system and thirty to four-hundredth as surroundings through exhaust gas). Exhaust gases like a shot going the engine will have temperatures as high as 842-1112°F [450-600°C]. Consequently, these gases have high H, carrying away as exhaust emission. Efforts are often created to style additional energy economical engine with higher heat transfer and lower exhaust temperatures; but, the laws of natural philosophy place a lower limit on the temperature of exhaust gases [5]. Fig. 1 shows total energy distributions from burning engine.

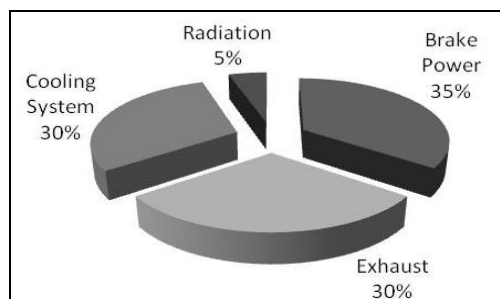

Fig 1: Total fuel energy content in I. C. engine

### A. Primary Procedure

Generating power from waste heat typically involves waste heat utilization from internal combustion engine to generate mechanical energy that drives an electric generator. Electricity generation is directly from heat source such as thermoelectric and piezoelectric generator. A factor that affects on power generation is thermodynamic limitations for different temperature range. The efficiency of power generation is heavily depended on the temperature of the waste heat gas and mass flow rate of exhaust gas.

### B. Secondary Procedure

The exhaust pipe contains a block with thermo electric materials that generates a direct current, thus providing for at least some of the electric power requirements. In which two different semiconductors are subjected to a heat source and heat sink. A voltage is created between two conductors. It is based on the seeback effect. The Cooling and Heating is done by applying electricity. It is low efficiency approximately (2 to 5%) and high cost.

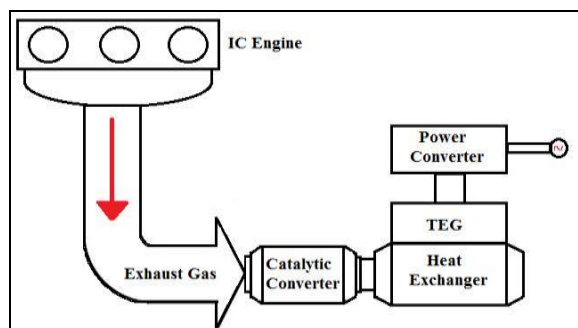

Fig 2: Thermoelectric Generator

Fig. 2 shows thermoelectric generator and its components. Thermoelectric devices may potentially produce twice the efficiency as compared to other technologies in the current market [20]. Thermo Electric Generator is used to convert thermal energy from different temperature gradients existing between hot and cold ends of a semiconductor into electric energy this phenomenon was discovered by Thomas Johann Seebeck in 1821 and called the “Seebeckeffect”. The device offers the conversion of thermal energy into electric current in a simple and reliable way. Advantages of Thermo Electric Generator include free maintenance, silent operation, high reliability and involving no moving and complex mechanical parts. Recycling and reusing waste exhaust gas can not only enhance fuel energy use efficiency, but also reduce air pollution [21]. Thermal power technology such as the Thermo Electric Generator arises, therefore, significant attention worldwide. Thermo Electric Generator is a technology for directly converting thermal energy into electrical energy. It has no moving parts, is compact, quiet, highly reliable and environmentally friendly. Because of these merits, it is presently becoming a noticeable research direction. The mathematical model of a Thermoelectric Generator device using the exhaust gas of vehicles as heat source, and preliminary analysis of the impact of relevant factors on the output power and efficiency of Thermo Electric Generator. Analysis of model simulates the impact of relevant factors, including vehicles exhaust mass flow rate, temperature and mass flow rate of different types of cooling fluid, convection heat transfer coefficient, height of PN couple, the ratio of external resistance to internal resistance of the circuit on the output power and efficiency. The results of analysis shows that the output power and efficiency increase significantly by changing the convection heat transfer coefficient of the high-temperature-side than that of low-temperature-side. Pilot program is made to investigate the applicability of thermoelectric generators to the recovery of medium-temperature waste heat from a low-power stationary diesel engine. Experimental investigation to the optimum operating conditions to achieve maximum power outputs from the waste heat recovery system [23]. Study on waste heat recovery system by using thermoelectric generator from internal combustion engine reviews the main aspects of thermal design of exhaust-based thermoelectric generators (ETEG) systems [24]. Analysis of thermoelectric generator for power generation from internal combustion engine shows results as 20% of energy releasing for the waste heat from engine. It is able to 30-40% of the energy supplied by fuel depending on engine load [25].

### 3. Two stroke petrol engine testing procedure

The waste heat recovery system consists of

1. Two stroke petrol engine,
2. Gas turbine,
3. Dynamo,
4. Battery,
5. Inverter and
6. Thermoelectric generator.

The specification of the two stroke petrol engine is shown in the Table 1.



**Fig 3:** Specification of the two stroke petrol engine

**Table 1:** Specification of the two stroke petrol

Engine Type	Two stroke petrol engine
Bore/Stroke	50x50 mm
Piston displacement and compression ratio	98.2 cm <sup>3</sup> and 6.6:1 respectively
Maximum Torque and power	9.614 N-m at 5, 500 rpm and 7.5 ps at 5,800 rpm respectively

#### A. Batteries

In an isolated system, batteries are used for storage of excess energy converted into electrical energy. It is necessary that the overall system be optimized with respect to available energy and local demand pattern. Li-ion batteries are used in the system for energy storage.

#### B. Inverter

An inverter has been used to convert the DC power into AC power.

#### C. TE-Generator

TEGs are made from thermoelectric modules which are solid-state integrated circuits that employ three established thermoelectric effects known as the Peltier, Seebeck and Thomson effects. Their construction consists of pairs of p-type and n-type semiconductor materials forming a thermocouple. These thermocouples are then connected electrically forming an array of multiple thermocouples called as thermopile. They are then sandwiched between two thin ceramic wafers. When heat and cold are applied this device then generates electricity.



**Fig 4:** Thermoelectric generator mounted on exhaust system.

#### 4. Results and Discussion

The waste heat recovery is done using the velocity and the temperature on the surface of the primary exhaust pipe. The power is generated instantaneously since the turbine and the generator are coupled together. In accordance with throttle input, the velocity of exhaust gases varies directly. This energy is used to run the turbine and the output is Measured

and tabulated in Table 2.

**Table 2:** Experimental Results

S. No.	V (Volts)	I (Amps)	Power (Watts)	Speed rpm
1.	0.80	0.47	0.376	46
2.	1	0.5	0.5	50
3.	0.16	0.68	1.09	315
4.	3.5	0.7	2.45	435
5.	3	0.8	2.4	470
6.	4	0.9	3.6	700
7.	4.6	1.1	4.76	900

#### 5. Conclusion

The combined heat and power system offers additional benefits like reduction in the emission of carbon dioxide (CO<sub>2</sub>), sulphur dioxide (SO<sub>2</sub>) and oxides of nitrogen (NO<sub>x</sub>) for the same power and heat generation. This is achieved by using the waste heat recovery system and can be installed on any equipment which generates heat and needs heat dissipation to reduce the pollution during the operation of machines in addition to the auxiliary power generation. This auxiliary power can be utilized for the operation of main mechanism. The efficiency of the equipment increases considerably since the waste heat is being utilized for the useful work. This system reduces the cost of operation by reducing the consumption of fuel. The size of all the flue gas handling equipment such as fans, stacks, ducts, burners, etc., is reduced. The consumption of auxiliary power is also reduced since the reduction in size of all the auxiliary equipment. The experimental performance testing has shown that the overall efficiency of two stroke petrol engine installed with and without the waste heat recovery system is 29.67% and 29.2% respectively when the power extraction was 90W. It is also observed that the consumption of fuel decreased by 4%. This experimental study has revealed that the use of waste heat recovery system is more efficient for extracting the energy wasted in various process industries.

#### 6. References

1. Basel Ismail I, Wael Ahmed H. Thermoelectric Power Generation Using Waste-Heat Energy as an Alternative Green Technology, Recent Patents on Electrical Engineering. 2009; 2:27-39.
2. Hou Xuejun, Xiao Peng. Computational Models Analysis of Diesel Engine Exhaust Waste Heat Recovery, International Conference on Ecology, Waste Recycling, and Environment Advances in Biomedical Engineering., Vol.7, 227-239.
3. J S Jadhao, D G Thombare (2013), Review on Exhaust Gas Heat Recovery for I.C. Engine, International Journal of Engineering and Innovative Technology (IJEIT), Volume 2, Issue 12, 147-159.
4. Janak Rathavi, Amitesh Paul, G R Selokar, International Journal of Computational Engineering Research, ISSN: 2250-3005, 7.
5. Jumade SR, Khond VW, Rasoni GH. International Journal of Engineering Research & Technology (IJERT). 2012; 1(10):6.
6. Marian Brazdil, Jiri Pospisil. Thermoelectric Power Generation Utilizing the Waste Heat from a Biomass

- Boiler. *Journal of Electronic Materials*. 2013; 42(7):67-78.
7. Mohd. Izam Abd, Jahariah Sampe. Experimental investigation of thermoelectric generator modules with different technique of cooling system. *American Journal of Engineering and Applied Sciences*. 2013; 6(1):1-7.
  8. Saidur R, Rezaei M, Muzammil WK, Hassan MH, Paria S, Hasanuzzaman M. Technologies to recover exhaust heat from internal combustion engines. *Renewable and Sustainable Energy Reviews*. 2012; 16.
  9. Endo T, Kawajiri S, Kojima Y, Takahashi K, Baba T, Ibaraki S, Takahashi T. Study on Maximizing Exergy in Automotive Engines, SAE Int. Publication, 2007.
  10. Nantha Gopal K, Rayapati Subbarao, Pandiyarajan V, Velraj R. Thermodynamic analysis of a diesel engine integrated with a PCM based energy storage system. *International Journal of Thermodynamics*. 2010; 13(1):15-21.
  11. Hakan Özcan, Söylemez MS. Thermal balance of a LPG fuelled, four stroke SI engine with water addition, *Energy Conversion and Management*. 2006; 47(5):570-581.
  12. Sathiamurthi P. Design and Development of Waste Heat Recovery System for air Conditioning, *Unit European Journal of Scientific Research*. 2011; 54(1):102-110.
  13. Karellasa S, Leontaritisa AD, Panousisa G, Bellos AE, Kakaras E. Energetic And Exergetic Analysis of Waste Heat Recovery Systems In The Cement Industry. *Proceedings of ECOS 2012 - The 25th International Conference on Efficiency, Cost, Optimization, Simulation and Environmental Impact of Energy Systems June 26-29, 2012, Perugia, Italy*.
  14. Teng H, Regner G, Cowland C. Waste Heat Recovery of Heavy-Duty Diesel Engines by Organic Rankine Cycle Part I: Hybrid Energy System of Diesel and Rankine Engines, SAE Int. Publication 2007-01-0537, 2007.
  15. Hatazawa M. Performance of a thermo acoustic sound wave generator driven with waste heat of automobile gasoline engine, *Transactions of the Japan Society of Mechanical Engineers*. 2004; 70(689):292-299. Part B.
  16. Diego A Arias, Timothy A Shedd, Ryan K Jester. Theoretical analysis of waste heat recovery from an internal combustion engine in a hybrid vehicle, SAE paper 2006-01-1605.
  17. Vazquez J, Zanz-Bobi MA, Palacios R, Arenas A. State of the art of thermoelectric generators based on heat recovered from the exhaust gases of automobiles, *Proceedings of 7th European workshop on thermoelectric*, 2002.
  18. Hossain N, Bari S. Effect of Design-Parameters of Heat Exchanger on Recovering Heat From Exhaust of Diesel Engine Using Organic Rankine Cycle, *Proceedings of the International Conference on Mechanical Engineering 2011 (ICME2011) 18-20 December 2011, Dhaka, Bangladesh*.
  19. Johnson V. Heat-generated cooling opportunities in vehicles, SAE Technical Papers, No. 2002, 2002-01-1969.
  20. John B Heywood. *Internal Combustion Engine Fundamental*, Tata McGraw Hill Education Private Limited, Edition. 2011; pp 249-250.
  21. Ganeshan V. *Internal Combustion Engine*, Tata McGraw Hill Publishing Company Limited, Second Edition, 35:606-670.
  22. Doyle EF, Patel PS. Compounding the truck diesel engine with an organic rankine cycle system, 760343, Society of Automotive Engineers (SAE), 1976.
  23. James Conklin C, James Szybist P. A highly efficient six-stroke internal combustion engine cycle with water injection for in-cylinder exhaust heat recovery, *Energy*. 2010; 35(4):1658-1664.
  24. Saidur R, Rezaei M, Muzammil WK, Hassan MH, Paria S, Hasanuzzaman M. Technologies to recover exhaust heat from internal combustion engines, *Renewable and Sustainable Energy Reviews*. 2012; 16:5649-5659.
  25. Hou Xuejun, Gao Deli. Analysis of Exhaust Gas Waste Heat Recovery and Pollution Processing for Z12V190 Diesel Engine, Maxwell Scientific Organization, Res. J. Appl. Sci. Eng. Technol. 2012; 4:1604-1611
  26. Mhia Md. Zaglul Shahadat, Md. Nurun Nabi, Md. Shamim Akhter. Diesel Nox Reduction by Preheating Inlet Air, *Proceedings of the International Conference on Mechanical Engineering*, 2005.
  27. Karaosmanoglu F. Vegetable oil fuels: a review, *Energy Sources*. 1999; 21:221-231.
  28. Zhang X, Chau KT. An automotive thermoelectric–photovoltaic hybrid energy system using maximum power point tracking, *Energy Conversion and Management*. 2011; 52(1):641-7.
  29. Vazquez J, Sanz-Bobi M, Palacios R. State of the art of thermoelectric generators based on heat recovered from the exhaust gases of automobiles, In: *Proceedings of the seventh European workshop on thermoelectrics*, 2002.
  30. Yuchao Wang, Chuanshan Dai, Shixue Wang. Theoretical analysis of a thermoelectric generator using exhaust gas of vehicles as heat source, *Appl Energy* (2013), <http://dx.doi.org/10.1016/j.apenergy.2013.01.018>.
  31. Jihad G. Haidar and Jamil I. Ghojel. Waste Heat Recovery from the Exhaust of Low-Power Diesel Engine Using Thermoelectric Generators, *20th International Conference on Thermoelectric (2001)*, pp 0-7803-5908-9, 02001 IEEE.
  32. Saqr KM, Mansour MK, Musa MN. Thermal design of automobile exhaust based thermoelectric generators: objectives and challenges. *International Journal of Automotive Technology*. 2008; 9(2):155-160.